

SPRAYACTION
FR007 TECHNICAL DATA SHEET

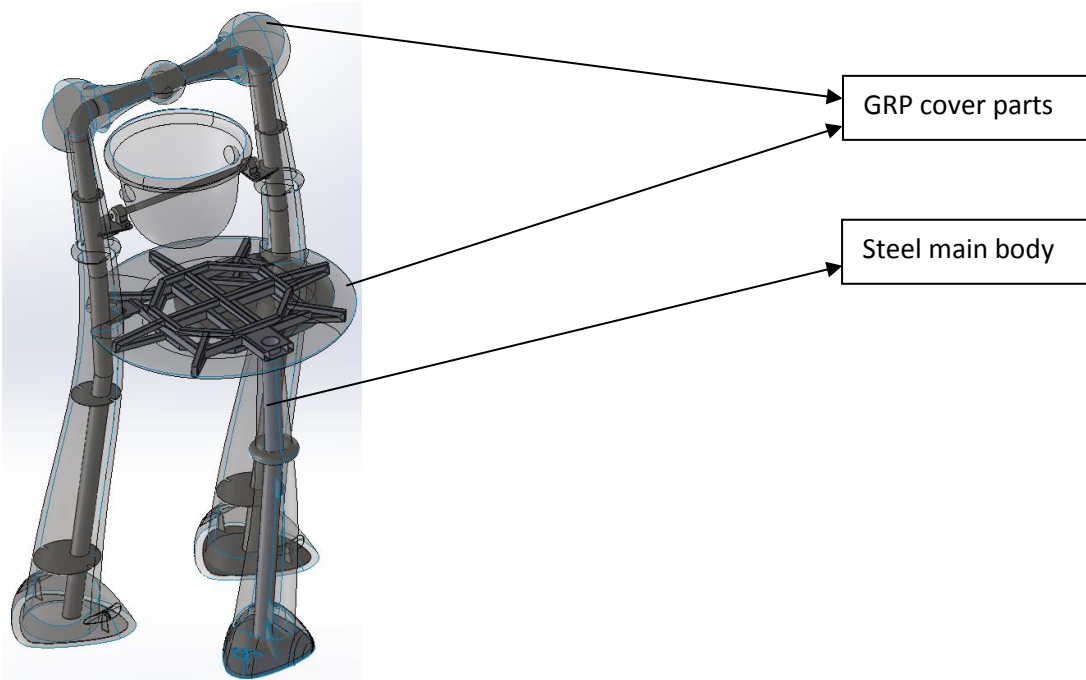

Product Summary

Product : FR007
Flow Rate : 10 m³/h
Pressure : 2 bar



Dimensions - 1/2

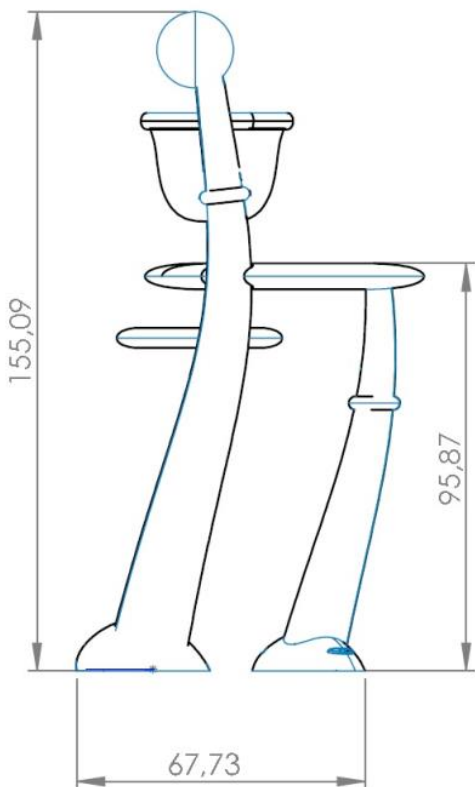

General Assembly

The delivered Spray action product code is FR007. This product consists of following components:

- Ø114 mm steel pipe as the main body,
- Ø240 mm steel flange for installation on the ground and for connection to the anchorage system,
- Chemical Anchorage system
- GRP (Glass Reinforced Plastic) feet and upper covers for accessorizing and camouflaging the feet connections



Splash zone

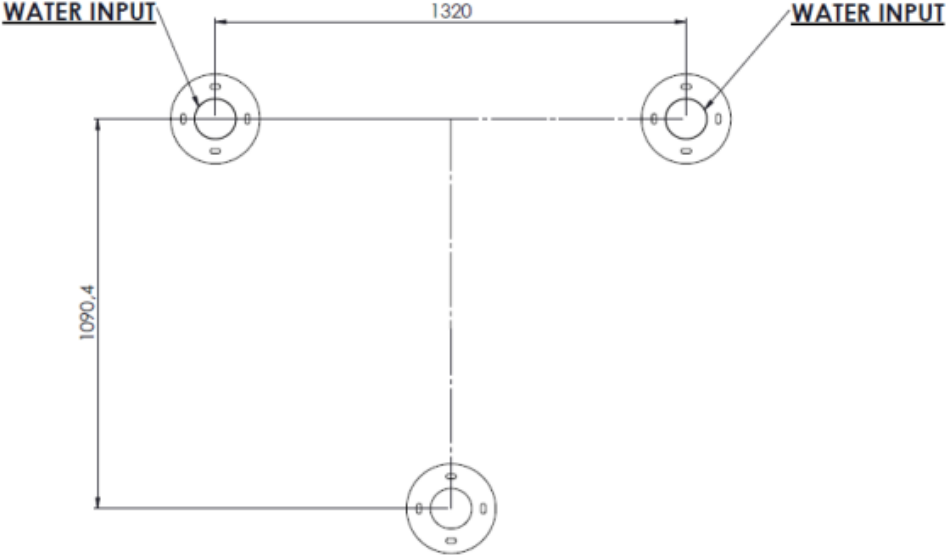

Anchorage System Installation

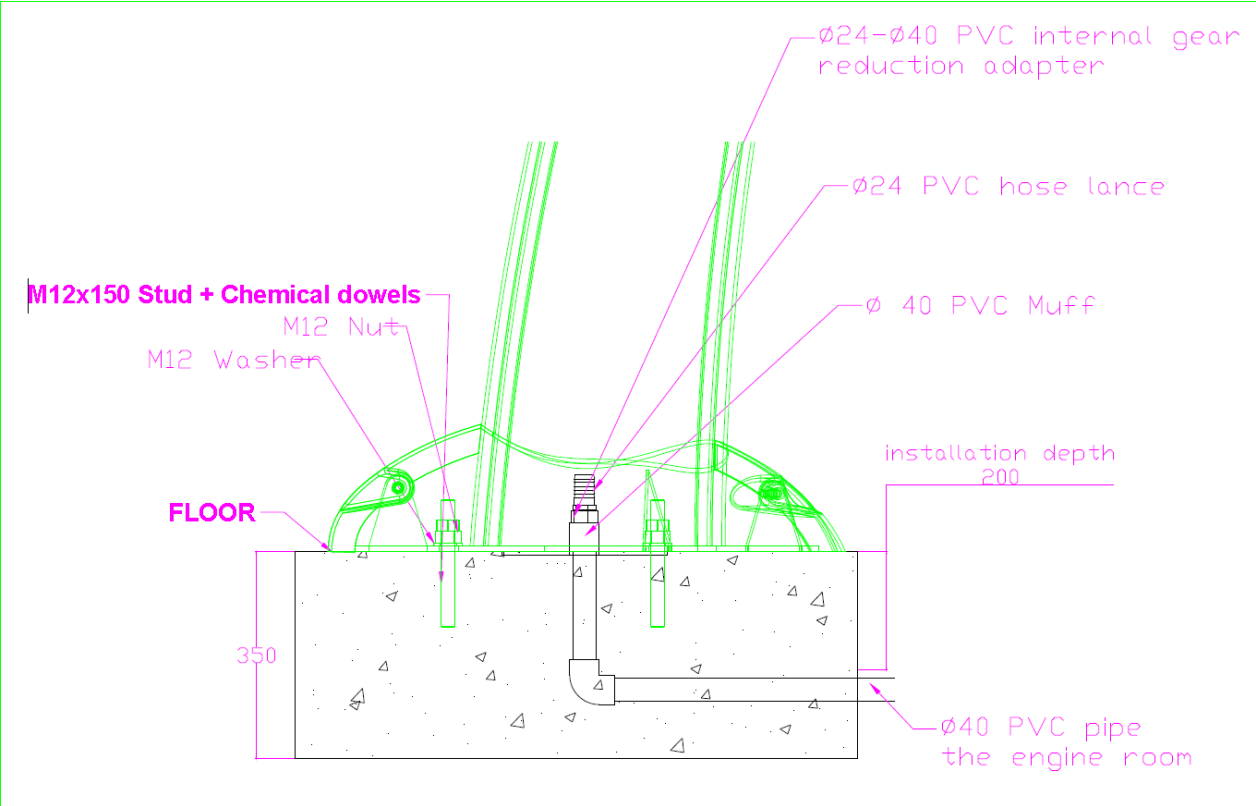

Installation Notes

- Installation should be performed by a qualified technician and all local safety codes should be applied.
- Filtration, circulation and piping systems are belong to customer.
- Pools or installation area must be of standard construction and pool water must be clean and free of suspended solids.
- In line strainers are required for proper removal of particles.
- Filtration and water turnover rates must adhere to local regulations and codes.

Package Include

1x FR007

12x M12 Stud

12x Chemical Dowel

Safety

Use of the equipment should be restricted to children of under ages 3 years old.

Only one person should use the equipment at any one time.

Any use of the equipment other than for its intended purpose is prohibited.

Incomplete equipment is a hazard and if unit becomes damaged it should be removed and use prohibited.

Users should avoid direct contact with water jet nozzles sensitive areas such as the eyes and ears.

Maintenance

The units contain moving parts and will require regular maintenance and periodic replacement of parts over an extended period of time. If unit is to sit idle for any long period of time lines should be purged of all standing water. Care should be taken when moving or working on the units to protect painted surfaces from unnecessary damage.

It is recommended that the equipment not be used in temperatures less than zero degrees centigrade. The units should be stored indoors during off season use.

Water Parameters

PARAMETERS	UNIT	STDS	MIN	MAX
Free Chlorine	ppm	UHE4 DIN ISO - 7393-1 and 2 Aquatic Health Code, 1st Edition	0.3	1
Combined Chlorine	ppm	UHE4 DIN ISO - 7393-1 and 2 Aquatic Health Code, 1st Edition	0	0.2
pH		Aquatic Health Code, 1st Edition	7.2	7.5
Hardness (CaCO ₃)	ppm	To prevent scaling on the product value set by manufacturer	0	300
Total Alkalinity (TAC)	ppm	Aquatic Health Code, 1st Edition, ANSI ASP-11 2009	60	180
Cyanuric Acid (Stabilizer)	ppm	Aquatic Health Code, 1st Edition ANSI ASP-11 2009	2	100
Total Dissolved Solids (TDS)	ppm	To prevent scaling on the product value set by manufacturer	50	1000
Conductivity	μS/cm	To prevent scaling on the product value set by manufacturer	500	1500
Iron	ppm	To prevent scaling on the product value set by manufacturer	0	0.2
Copper	ppm	Aquatic Health Code, 1st Edition, ANSI ASP-11 2009	0	1.0
Bromine* If used	ppm	ANSI ASP-11 2009	1	8
Ozone* If used	ppm	Aquatic Health Code, 1st Edition	-	0,1
Temperature	°C	To prevent scaling on the product value set by manufacturer	10	30
Color of water	L=436 mm/m	EN ISO 7887	-	0,5
KMnO ₄ Consumption	mg/L as KMnO ₄	UHE4	-	3
Aluminum	ppm	UHE4 EN ISO 12020 EN ISO 11885 EN ISO 17294-2 ISO 10566	-	0,05
Trihalogenated methane	ppm	UHE4 DIN 38407-30 DIN EN ISO 15680 DIN EN ISO 10301:1997 (Method 2)	-	0,02
Legionella spec.		ISO 11731, EN ISO 11731	-	1000